

Engineered for the edge. Built for the future.



The SAFEmini is an ultra-compact, crypto agile, low-power, hardware-enforced 1G IPsec encryption device, integrating post-quantum cryptography (PQC). It targets edge applications where secure, resilient, and ultra-low latency communications are essential, and where portability, weight and size are critical factors in deployment.



Seamless Integration

Works with SAFEcore to provide unmatched security from core to edge.



Flexible Architecture

Allows mesh and point-to-point configurations—securely connecting clusters of SAFEminis or aggregating back to a central SAFEcore. Supports 10 simultaneous IPsec connections for Mesh deployments.



Security by Design

Built-in secure boot and secure attestation ensure end-to-end protection.



Interoperability

Compatible with third-party IPsec devices for seamless integration.



Effortless Management

SAFEmini and SAFEcore are centrally controlled for simplified deployment, even in the most demanding environments.



Easy Installation

Hidden mounting points perfect for desktop use or 1U rack mounting with additional Din Rail clips

SAFEmini

Ultra-Low Latency Encryption for Mission-Critical Deployments

As cyber threats evolve, securing real-time communications across critical infrastructure, government, and enterprise environments has never been more vital. SAFEmini, combined with SAFEcore, delivers hardware-enforced, ultra-low-latency encryption that protects sensitive data without compromising performance. Whether securing remote operations or high-speed transactions, Sitehop ensures encryption is no longer a bottleneck.

Key Capabilities & Use Cases

Operational Technology (OT) Security

Protects Critical National Infrastructure (CNI), including energy grids, industrial control systems, and smart city networks.

Real-Time Autonomous Systems

Enables ultra-low-latency encryption for autonomous vehicles, drones, and defence applications.

Financial Transactions & High-Frequency Trading

Ensures secure, sub-microsecond encryption without impacting speed-sensitive transactions.

Secure Government Communications

Protects classified data in multi-domain environments, from defence operations to secure diplomatic networks. Cloud and Hybrid Deployments - Provides seamless security from on-premise data centers to multi-cloud infrastructures.

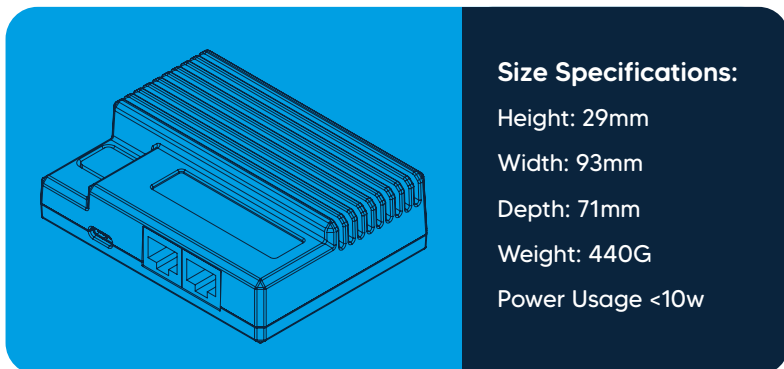

Size Specifications:

Height: 29mm

Width: 93mm

Depth: 71mm

Weight: 440G

Power Usage <10w



1Gbps full duplex

Our hardware-accelerated encryption delivers high-speed connections that carry data in both directions. Designed for flexibility, SAFEmini can work with any third-party encryptors already in your network to meet a wide range of network security needs.



10,000x lower latency

Protect your data without sacrificing speed. SAFEmini's accelerated encryption has up to 10,000 times lower latency than software-only solutions.



Future-proof Post Quantum Cryptography

PCQ compliance for edge applications



Crypto Agile

Change encryption standards using our remote, secure upgrade.



Centrally Managed

Manage SAFEmini from a central location with Sitehop SAFEms.

Sitehop SAFEnms

SAFE Series Network Management System (NMS)

Sitehop SAFEnms is a powerful Enterprise Network Management System that simplifies the deployment and management of global encryption devices. Its intuitive platform enables quick configuration of certificates and permissions.



Seamless transition to PQC

Future-proof your network with high-throughput security that's ready for tomorrow's challenges. Remote firmware updates, managed through Sitehop SAFEnms, ensure a smooth transition to Post Quantum Cryptography (PQC) while maintaining robust protection today.



REST API integration

Easily integrate Sitehop SAFEnms with your existing OSS/BSS or other management systems using its REST API. This ensures seamless interoperability with your operational workflows.



Role-based access control for all sites

Sitehop SAFEnms offers a flexible, secure role-based permissions system, allowing multi-tenanted configurations for complex networks. This enables precise access control, letting users manage individual sites and separate customers with ease, ensuring only authorized access.



Centralized dashboard

The dashboard delivers real-time insights into network performance, displaying total throughput and IPsec connectivity. Administrators can organize users into tenants and resource groups, enabling tailored monitoring, resource allocation, and customized security settings for efficient management and optimal performance.



Advanced monitoring and auditing

Maximize your network's performance with advanced data tracking, auditing, and logging features. These tools provide insight into network activity, ensuring your infrastructure operates at its full potential.



Built-In PKI

Sitehop SAFEnms includes a built-in PKI system, enabling users to create and manage certificates, including support for bringing your own third-party certificates.